

CO₂ Capture and Storage: Costs and Economic Potential

Carbon Sequestration: Is it Feasible?
Yale University

Howard Herzog
MIT
April 8, 2006

Coal and the Electricity Price

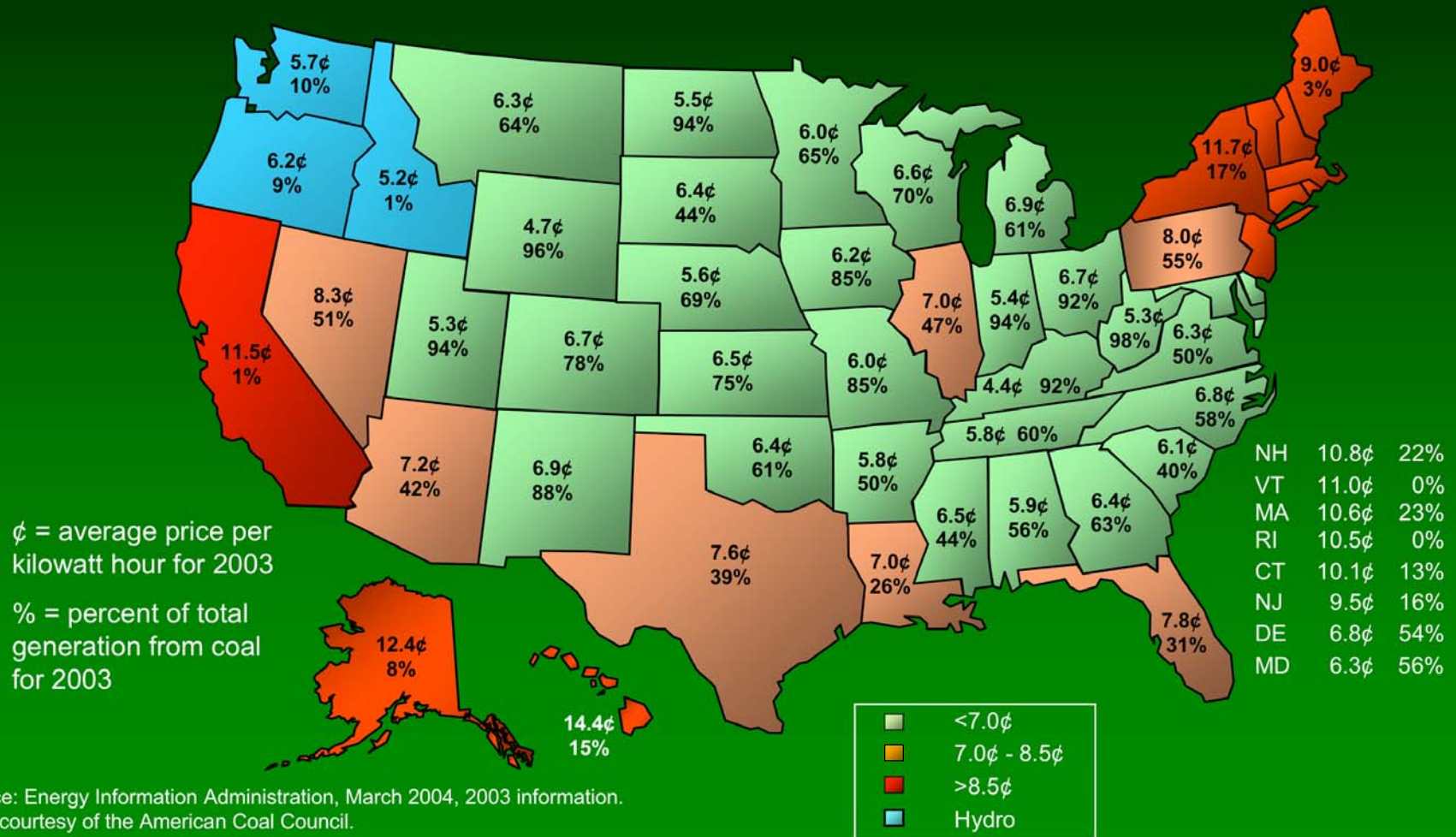

Source: Energy Information Administration, March 2004, 2003 information.
Slide courtesy of the American Coal Council.

Coal and the Electricity Price

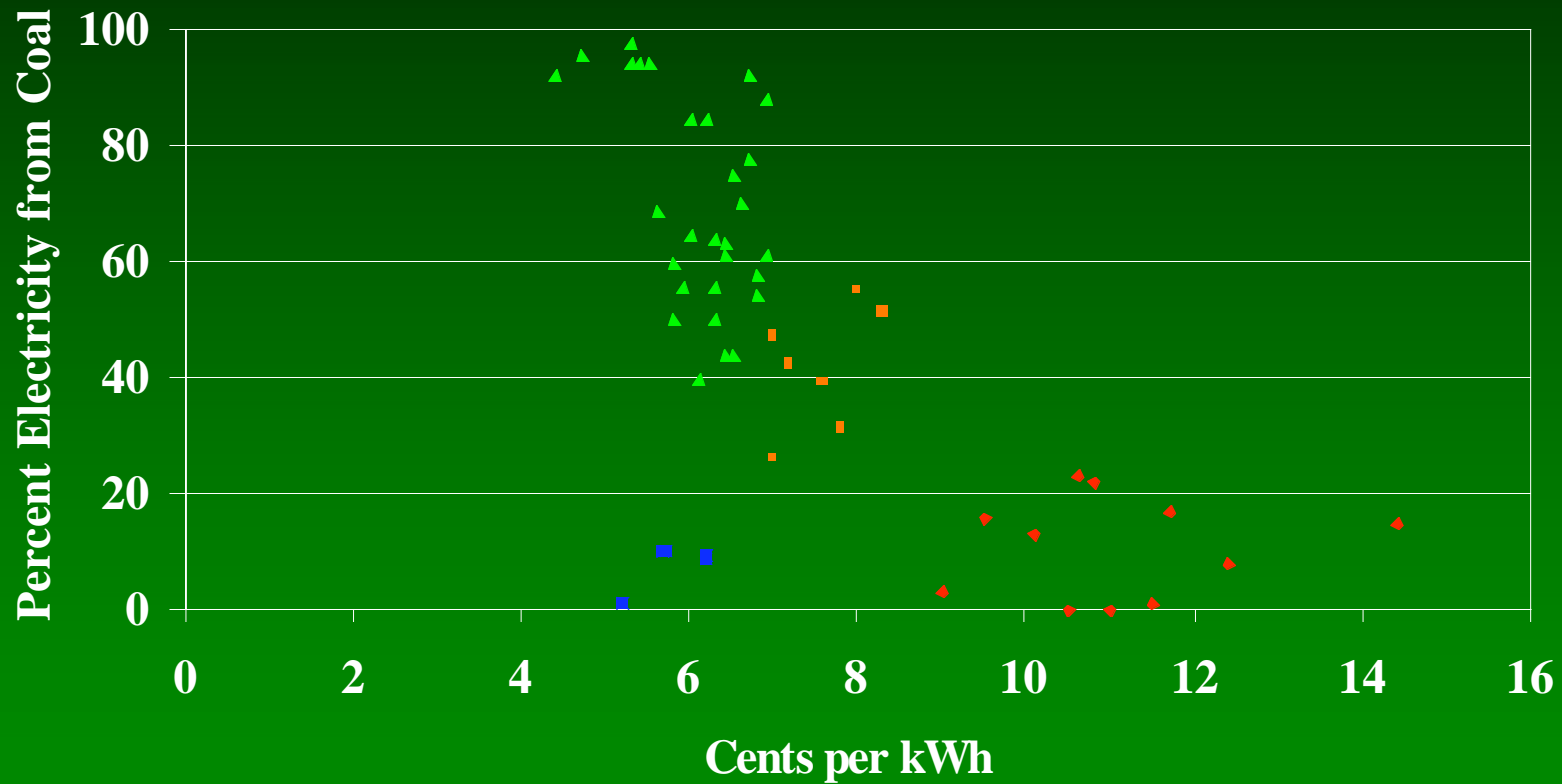

CCS - Sources

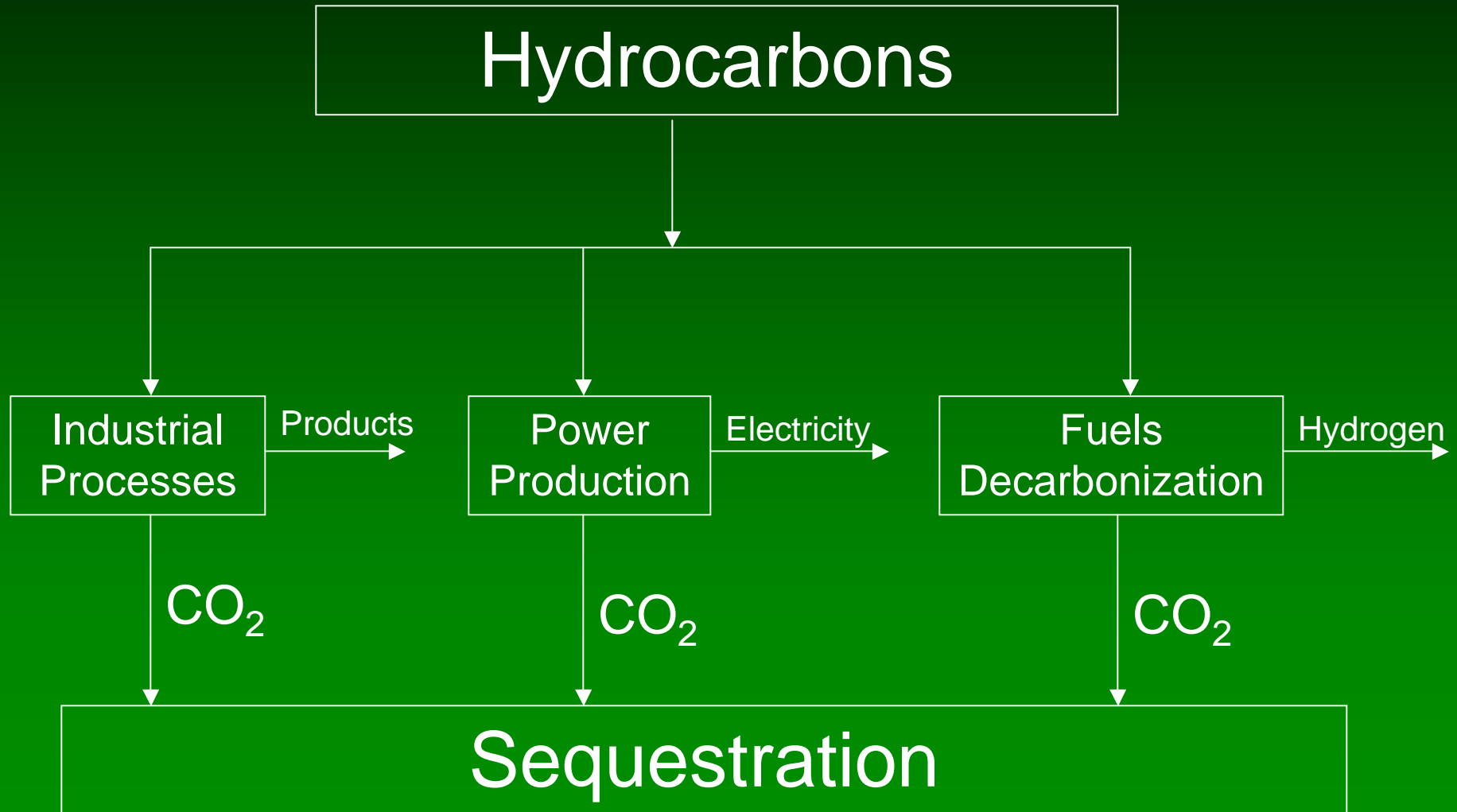

Approaches to CO₂ Capture from Coal-Fired Power Plants

- Post-combustion
- Pre-combustion
- Oxyfuel Combustion

Pulverized Coal (PC) Power Plant

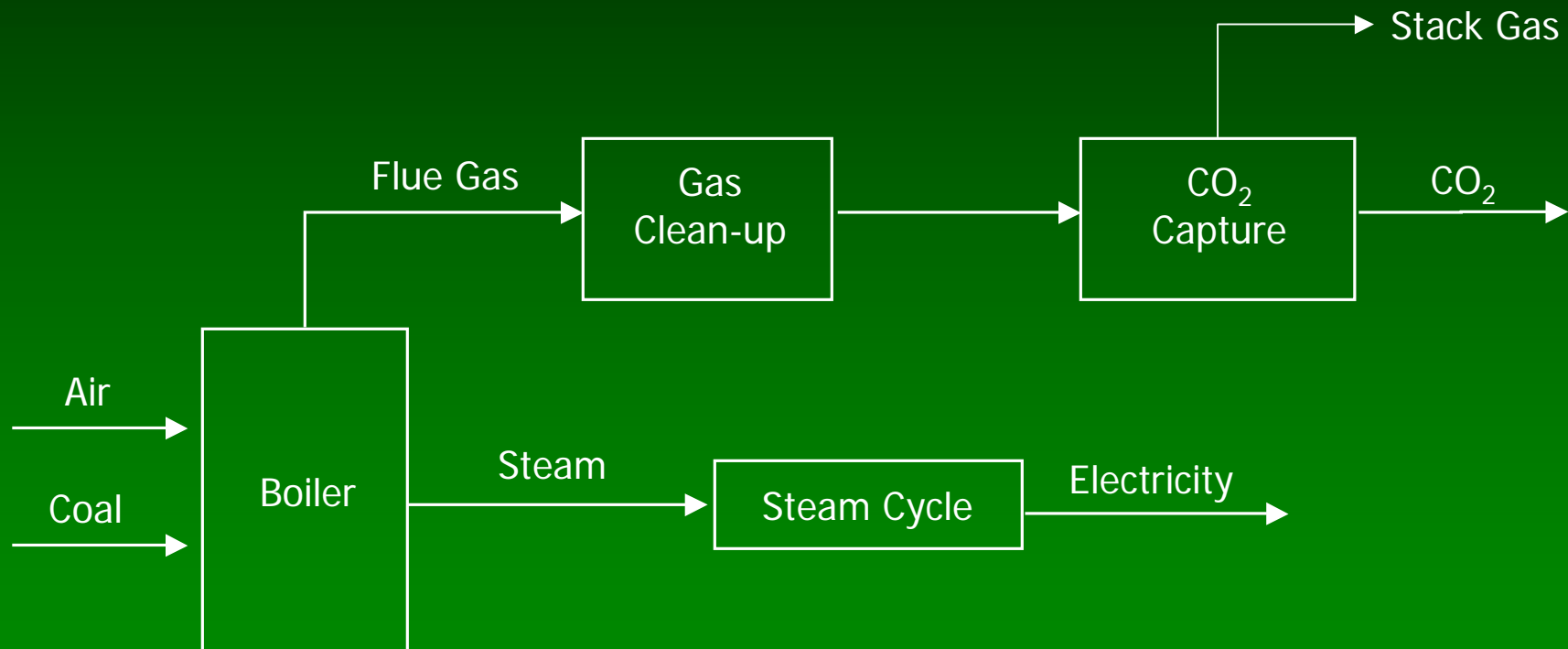

Schematic of Amine Process for CO₂ Capture

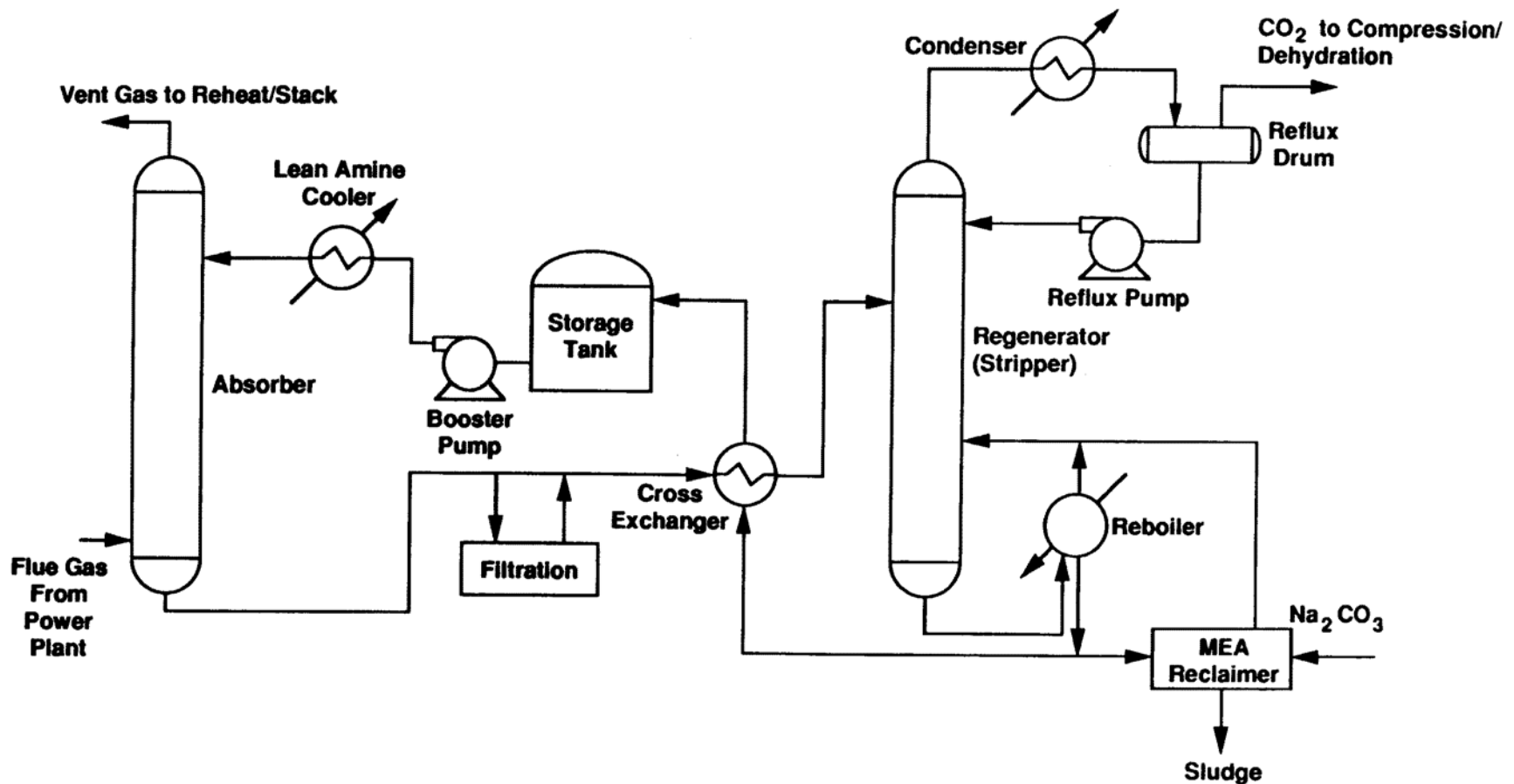

CO₂ Capture at a Coal-Fired Power Plant

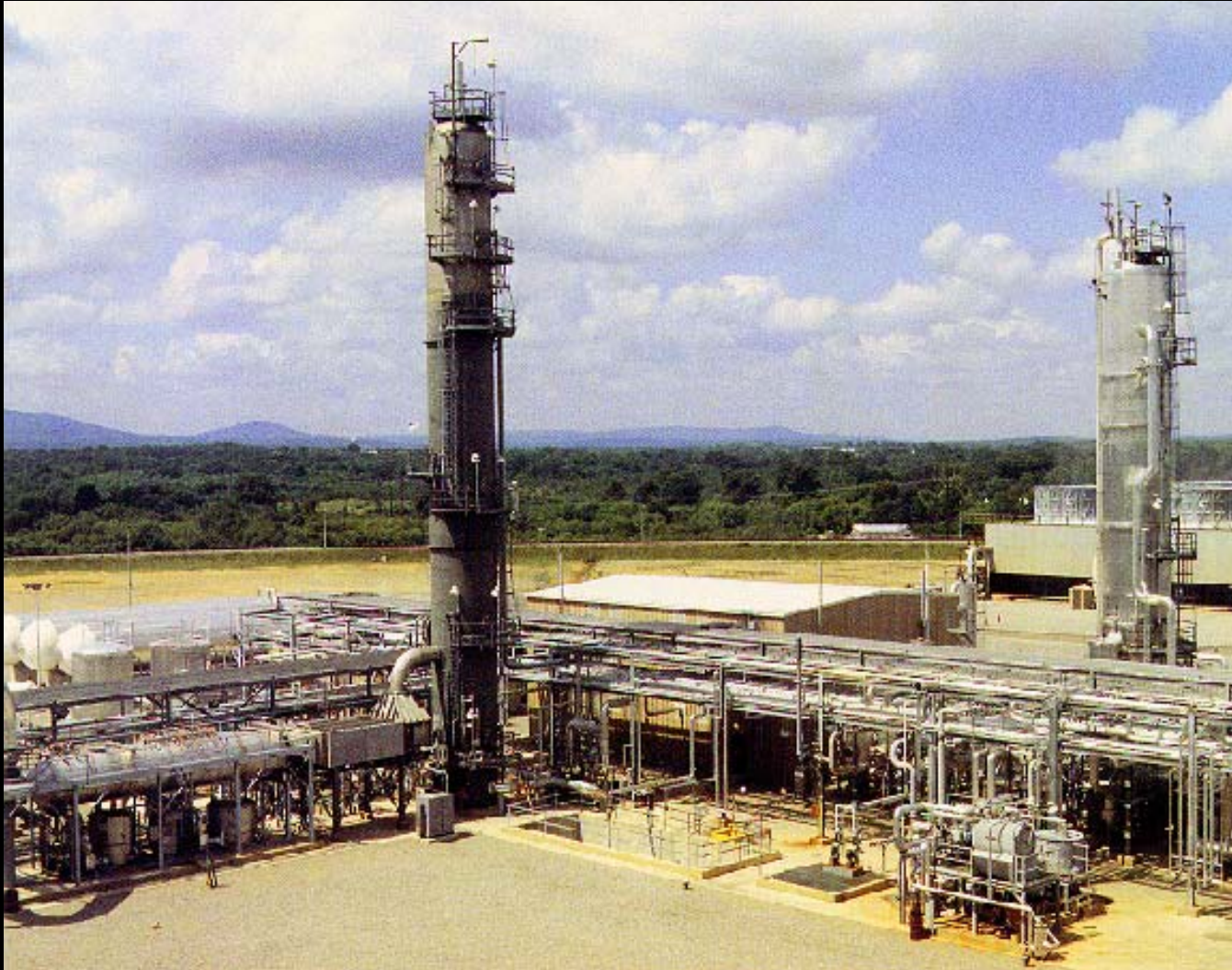

Source: ABB Lummus

E.S. Rubin, Carnegie Mellon

Parasitic Energy Requirements for PC Plant with Amine Capture

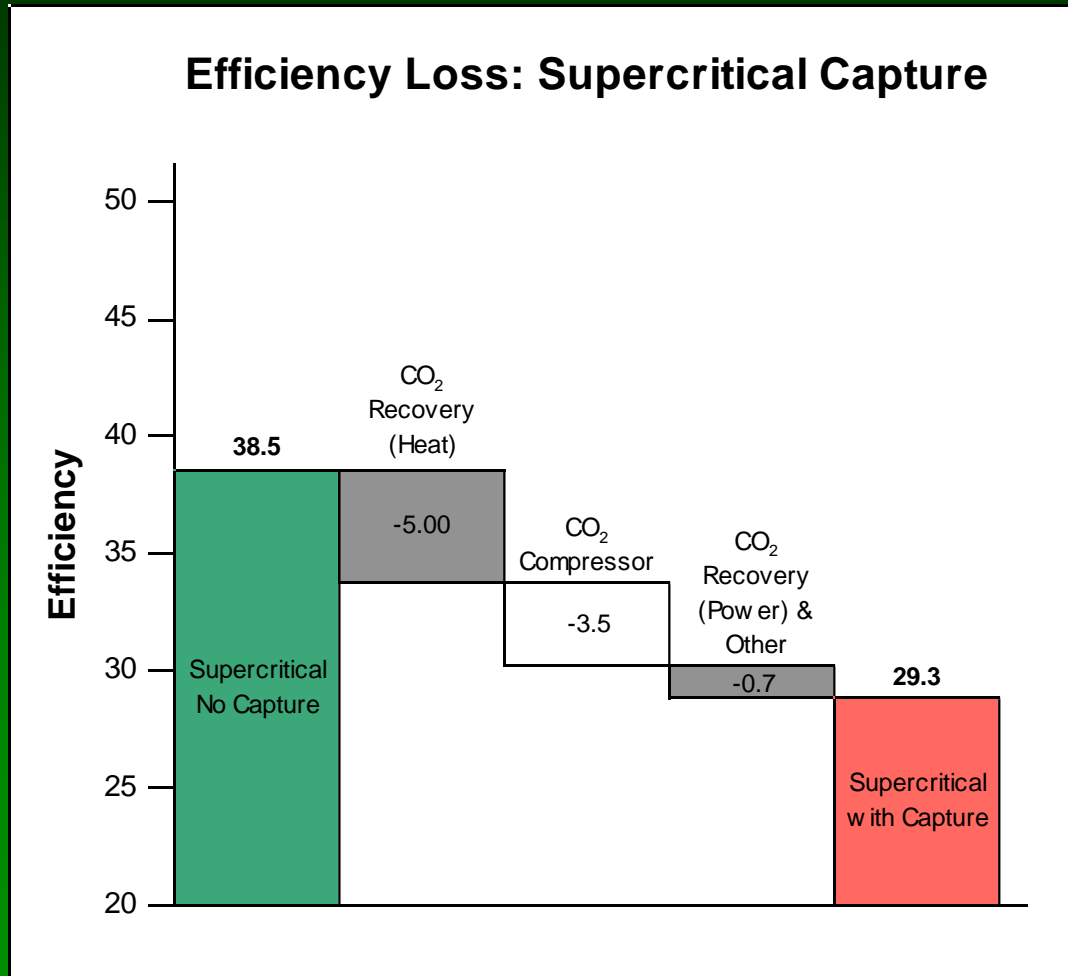

Approaches to Improve on Current Capture Process

- Improved post-combustion separation processes
- Alternate approaches – key difficulty with post-combustion is low CO₂ concentration and partial pressure
 - Partial Pressure = Total Pressure x Concentration
- PC plants
 - Total pressure = 1 atmosphere
 - CO₂ Concentration = 10-15%
 - Partial Pressure ~ 0.15 atm
- Gas plants' partial pressure as low as 0.03 atm

Integrated Gasification Combined Cycle (IGCC) Pre-Combustion Capture

- PC post-combustion
 - Partial Pressure ~ 0.15 atm
- IGCC pre-combustion
 - Removes CO_2 before dilution air
 - $P \sim 40$ atm, CO_2 concentration $\sim 40\%$
 - Partial Pressure ~ 16 atm

IGCC Power Plant

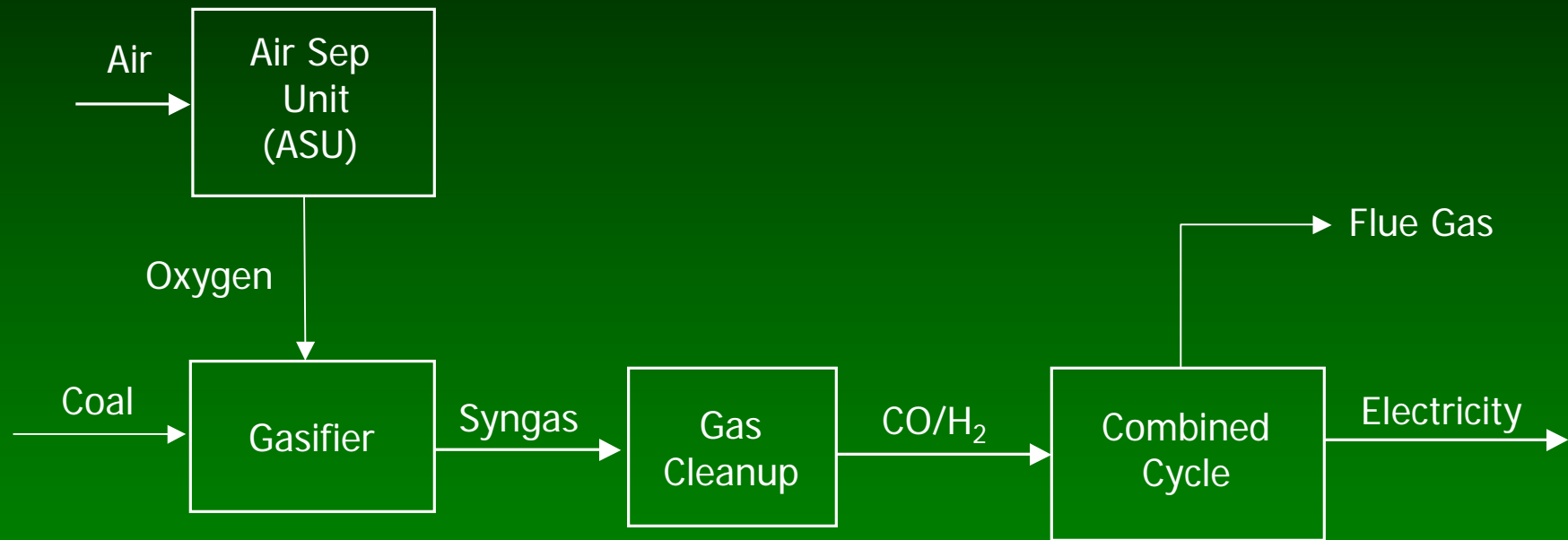

IGCC with Capture

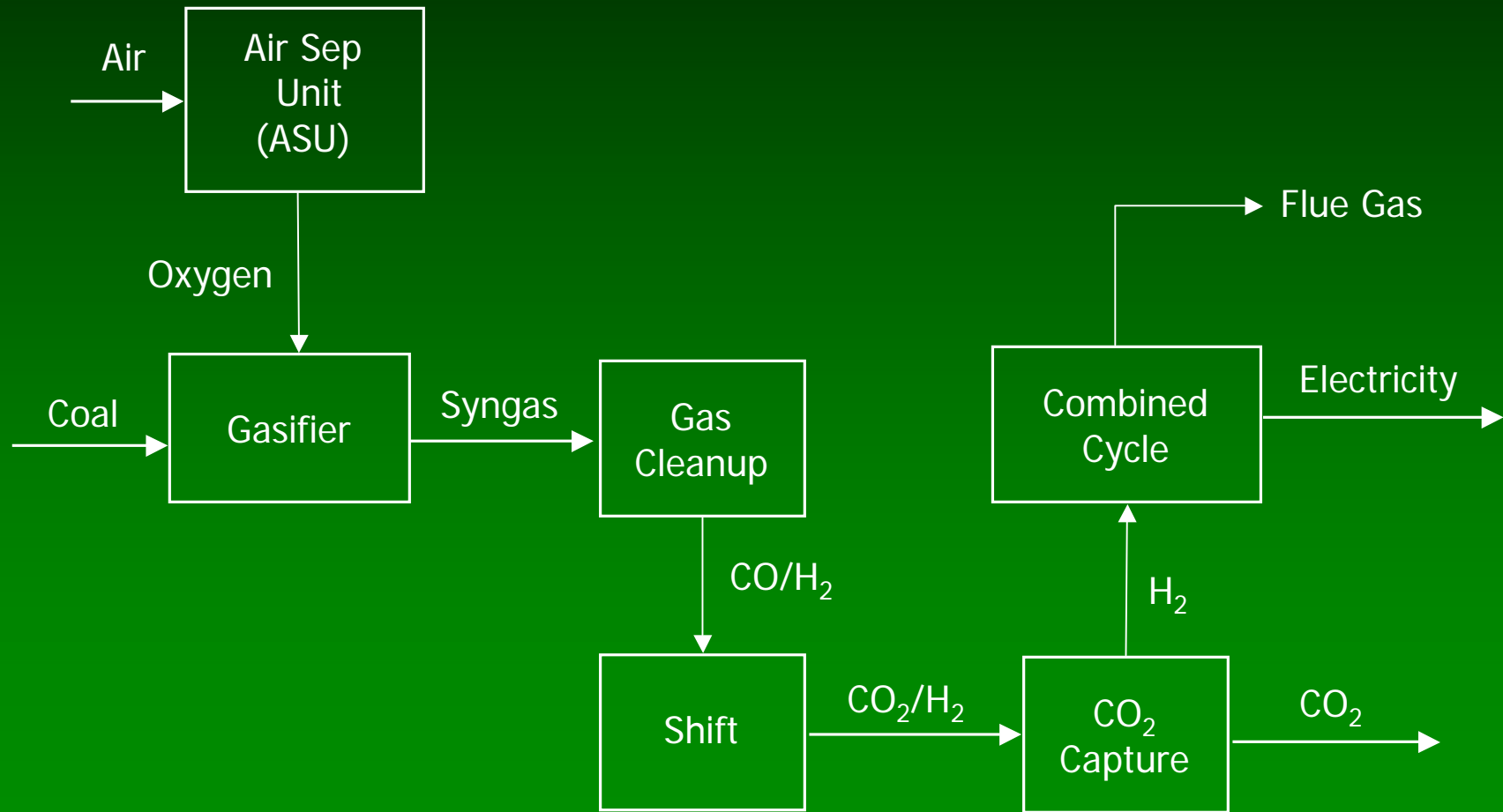

Parasitic Energy Requirements for IGCC with Capture

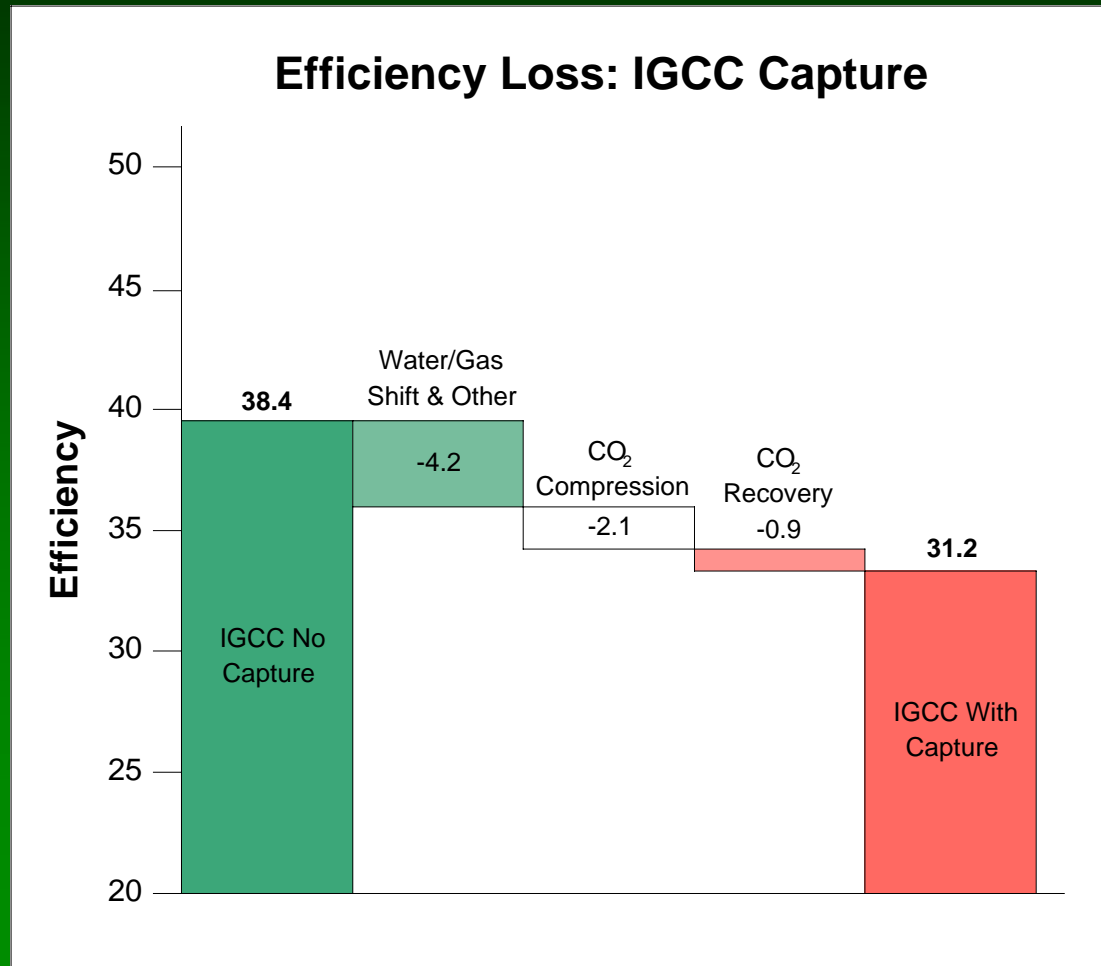

Oxyfuel Combustion Capture

- PC post-combustion
 - Partial Pressure ~ 0.15 atm
- IGCC pre-combustion
 - Partial Pressure ~ 16 atm
- Oxyfuel combustion
 - Removes N_2 (the major diluent) from air
 - $P \sim 1$ atm, CO_2 concentration ~ 90% (moisture free basis)
 - Partial Pressure ~ 0.9 atm

Oxyfuel Combustion Power Plant

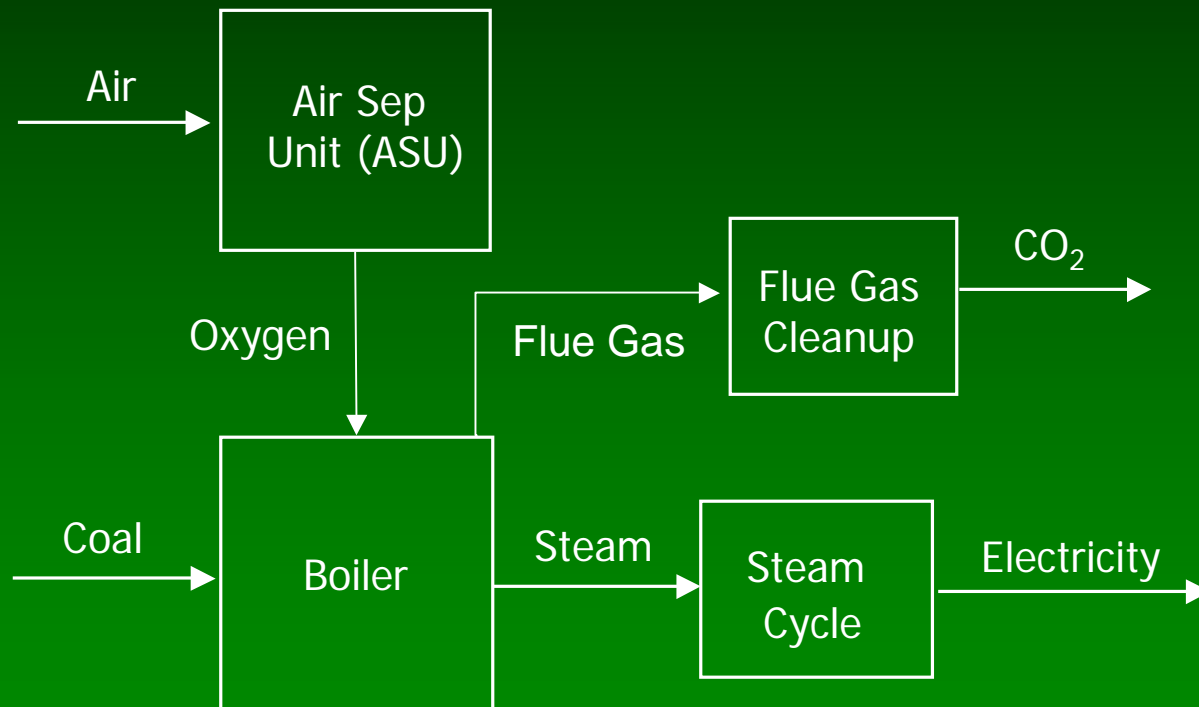

Parasitic Energy Requirements for Oxyfuel Capture

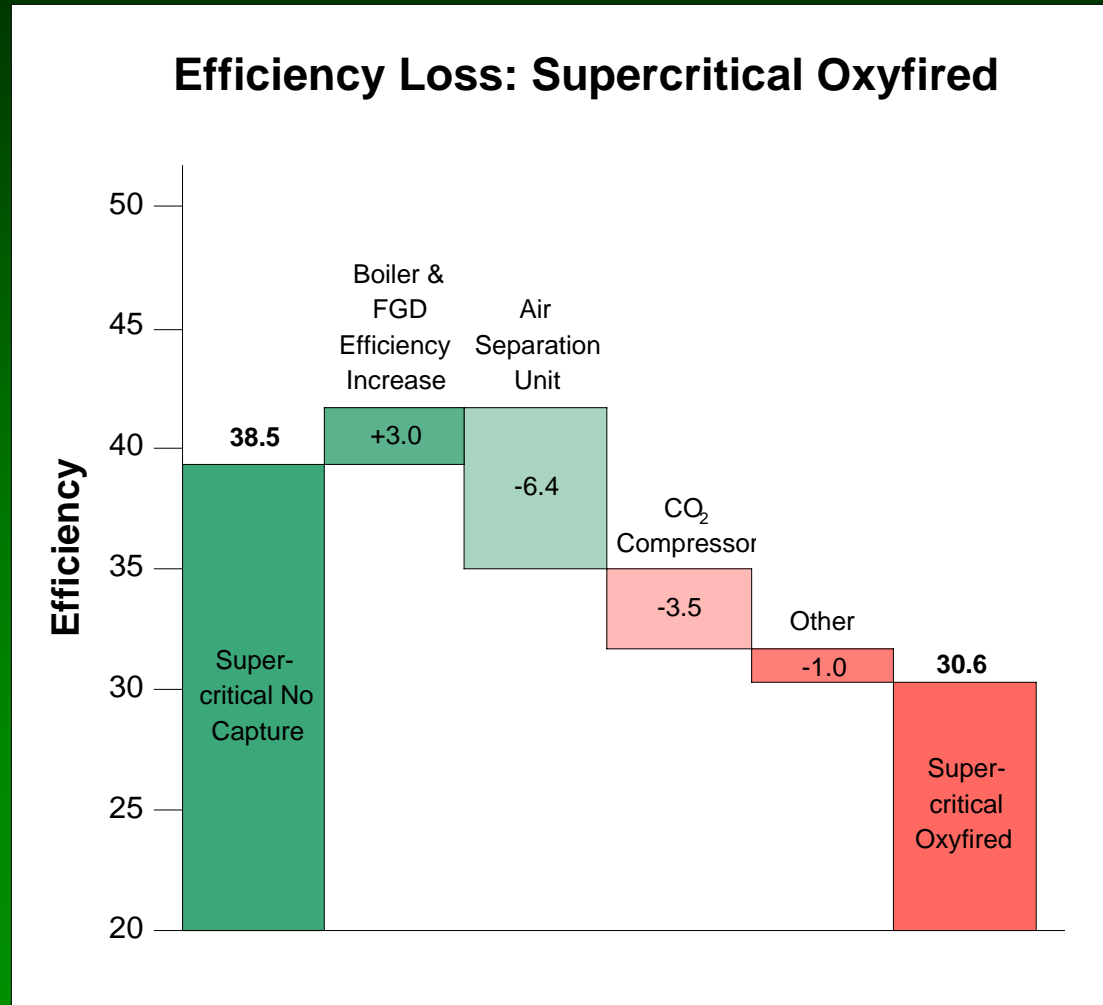

Capture and Compression Costs

- Output – high purity supercritical CO₂
- The numbers that follow are representative and are used to simply compare approaches
- There is much variability in the cost
 - Process Variability – plant location, coal type, criteria emission levels, process integration, etc.
 - Economic Variability – fuel costs, cost of capital, material and labor costs, capacity factor, etc.

Capture and Compression Costs

	Capital Investment	Power Output	Cost of Electricity
Post-Combustion	+23%	-24%	+61%
Pre-Combustion	+7%	-19%	+27%
Oxyfuel Combustion	+14%	-20%	+46%

Note: Assumes constant coal feed to power plant

Howard Herzog / MIT Laboratory for Energy and the Environment

Relative Cost of Electricity

	Without Capture	With Capture
Post-Combustion	1	1.61
Pre-Combustion	1.07	1.36
Oxyfuel Combustion		1.46

CO₂ Capture Projects Announced

Company	Location	Feedstock	Size (MW)	Capture	CO ₂ Fate
various	various	Coal/Gas	<50	Post	Markets
Statoil/Shell	Norway	Gas	860	Post(?)	EOR
Vattenfall	Germany	Coal	30 MW _{th}	Oxy	Sequestration
FutureGen	USA	Coal	275	Pre	Sequestration
RWE	Germany	Coal	450	Pre	Sequestration
Monash	Australia	Coal	?	Pre	EOR
BP	Scotland	Gas	350	Pre	EOR
BP	USA (CA)	PetCoke	500	Pre	EOR

Transport

- Restrict discussion to pipelines
- Key Variables
 - Length of the pipe
 - Location and terrain
 - Scale

Cost of CO₂ Pipeline Transport

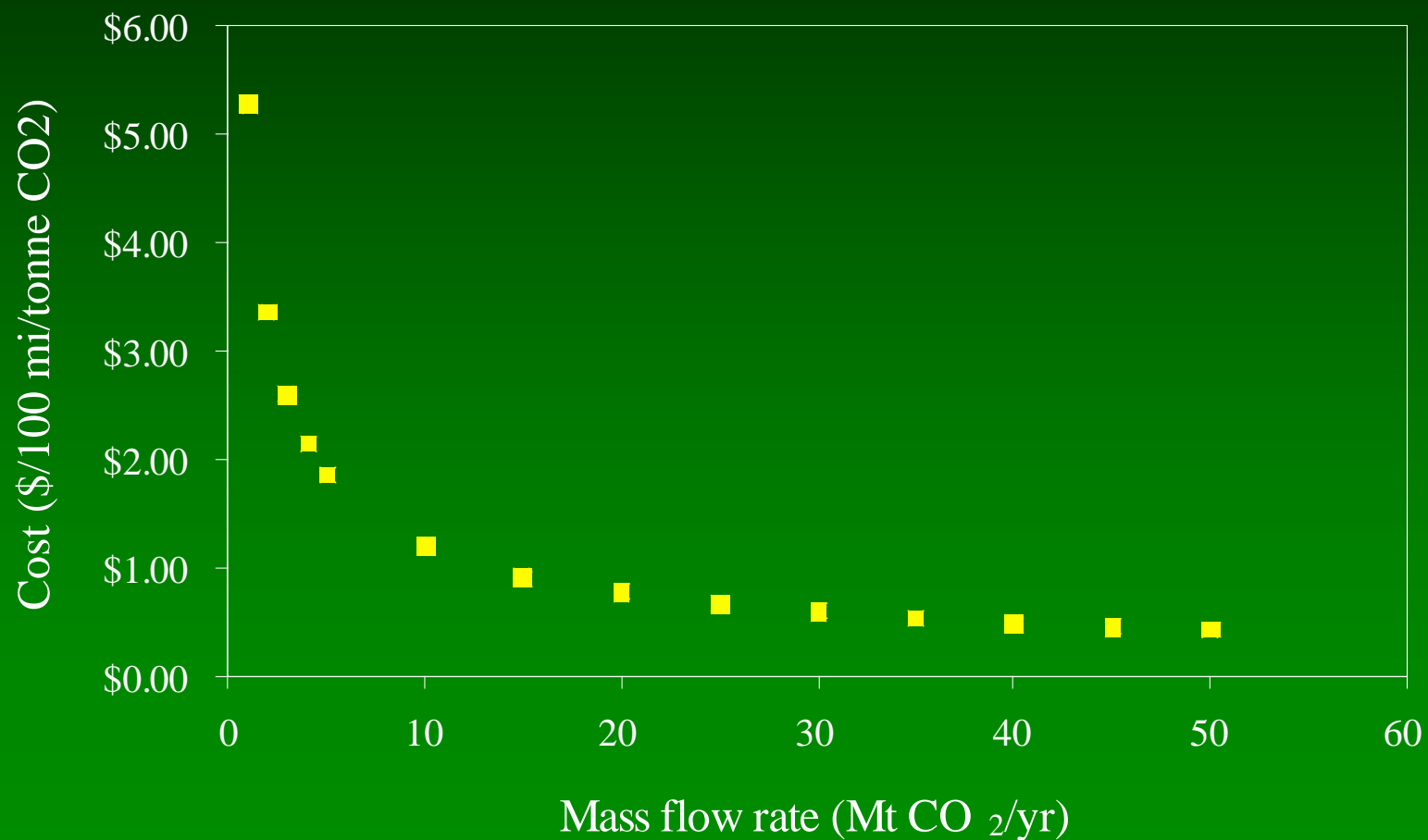

Land Construction Costs of Natural Gas Pipeline (1989-1998) versus Pipe Diameter

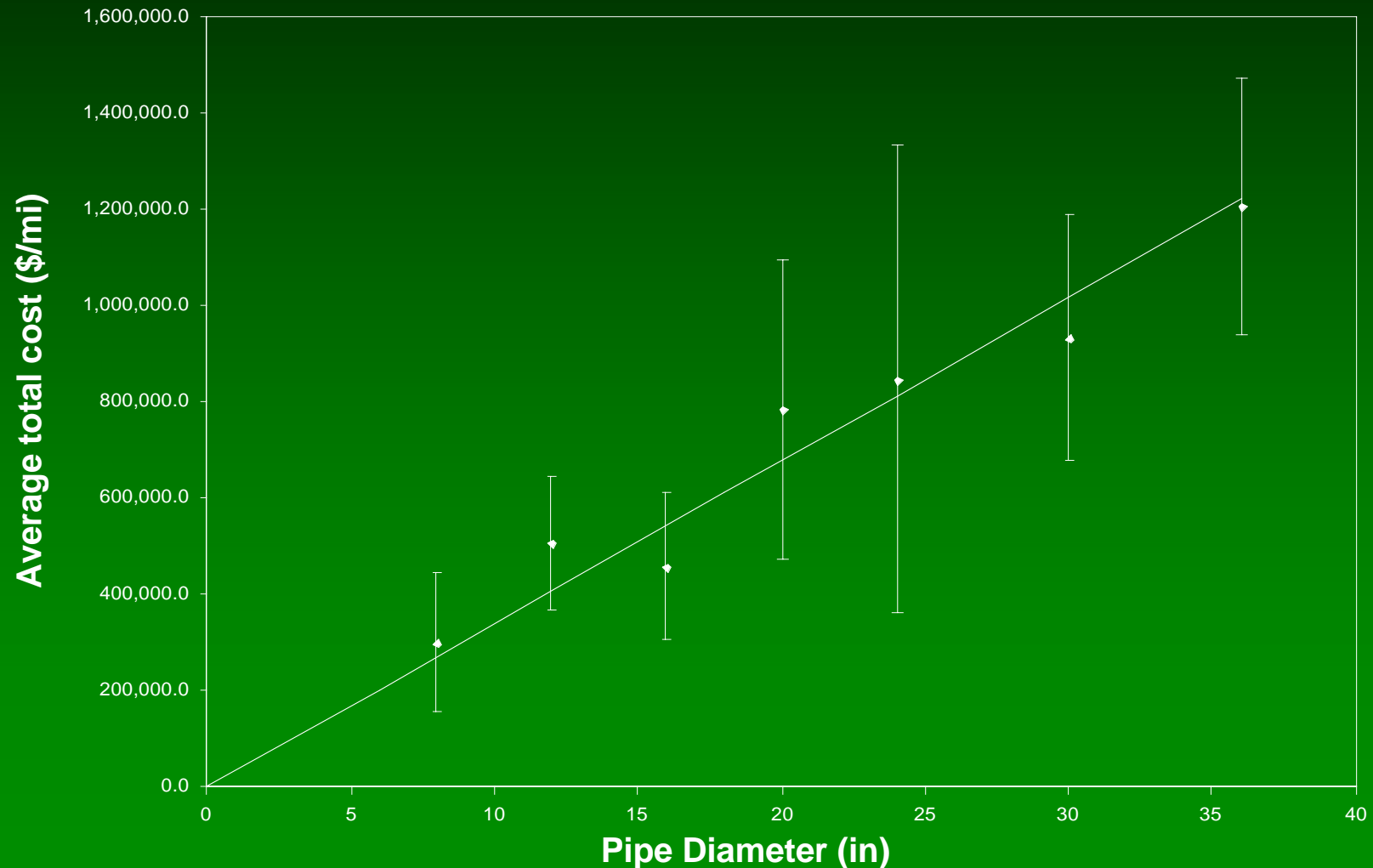

Howard Herzog / MIT Laboratory for Energy and the Environment

Injection Costs

Key Variables

- Type of Reservoir
- Reservoir Properties
 - Porosity
 - Depth
 - Pressure
 - Permeability
 - Thickness
 - Volume

Cost of CO₂ Transport and Injection

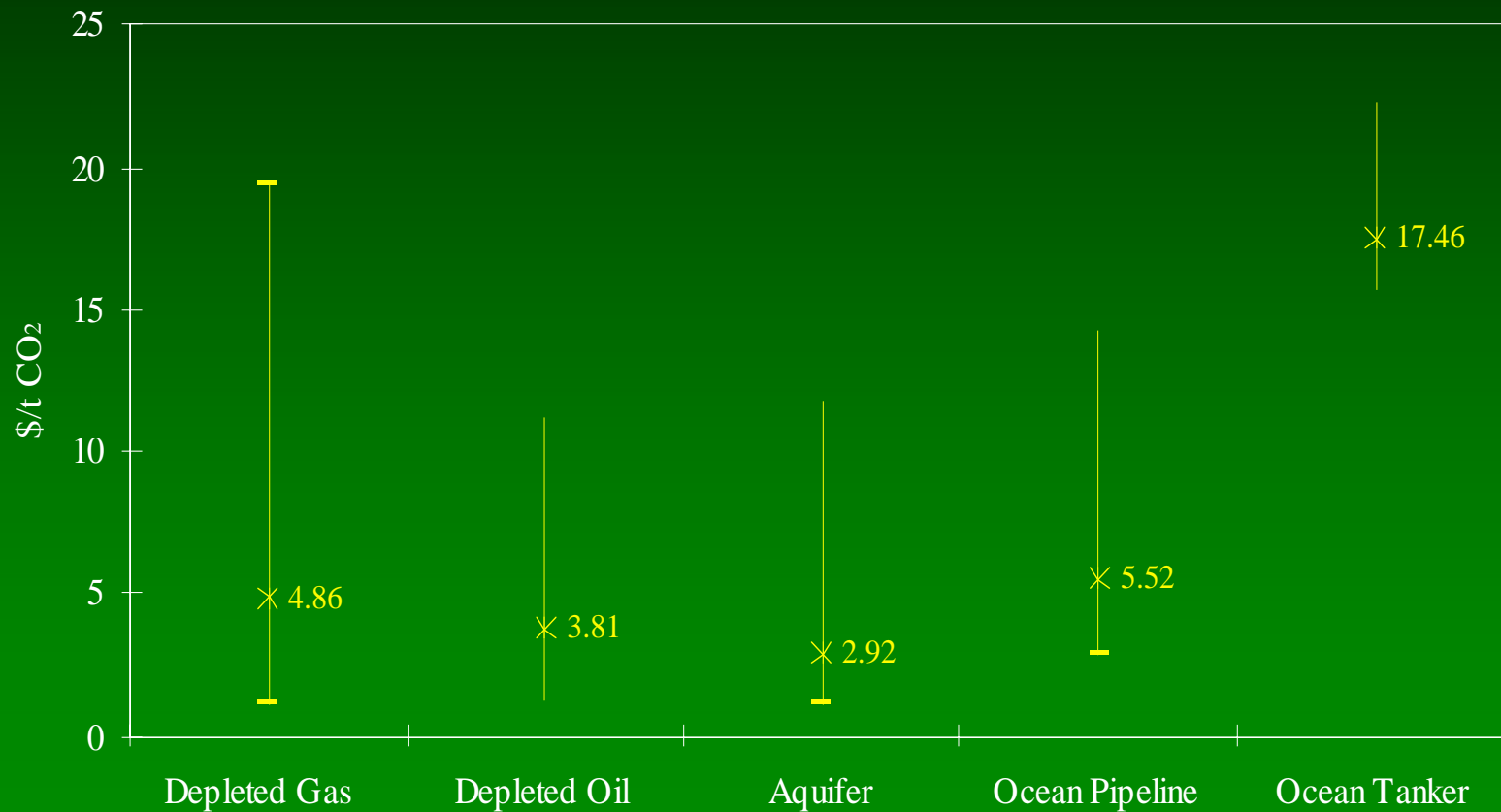

Mitigation Costs for CCS

Type of Capture Plant	Cost (\$/tCO ₂ avoided)
Post-combustion Supercritical PC	45
Oxyfuel Supercritical PC	35
Pre-Combustion IGCC	29

Assumptions:

- Base case is Supercritical PC
- Uses technology available today
- Assumes an nth plant (versus 1st of a kind)
- Transport/storage cost is \$5/tCO₂

Mitigation Costs

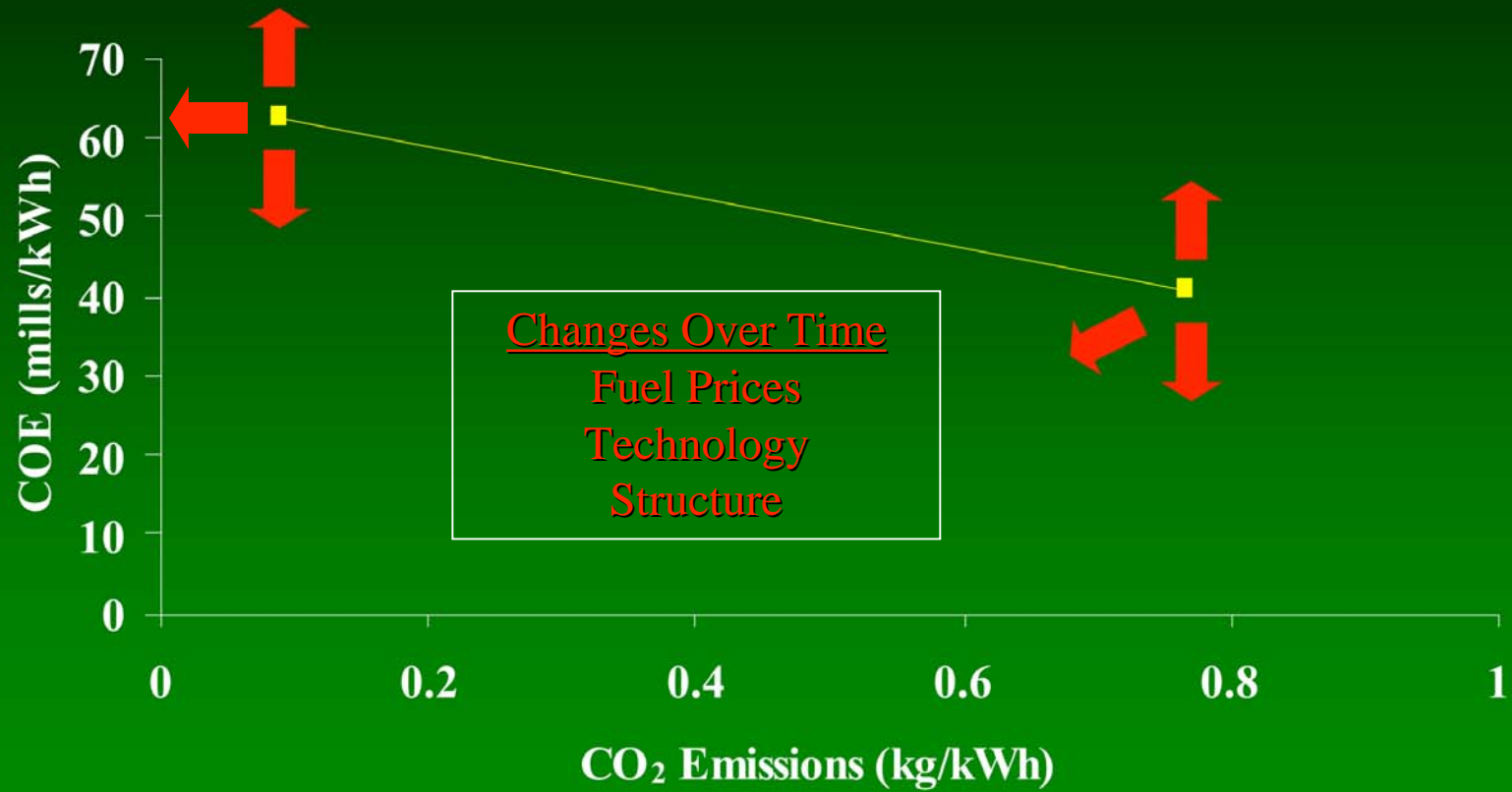

IPCC Special Report

Costs

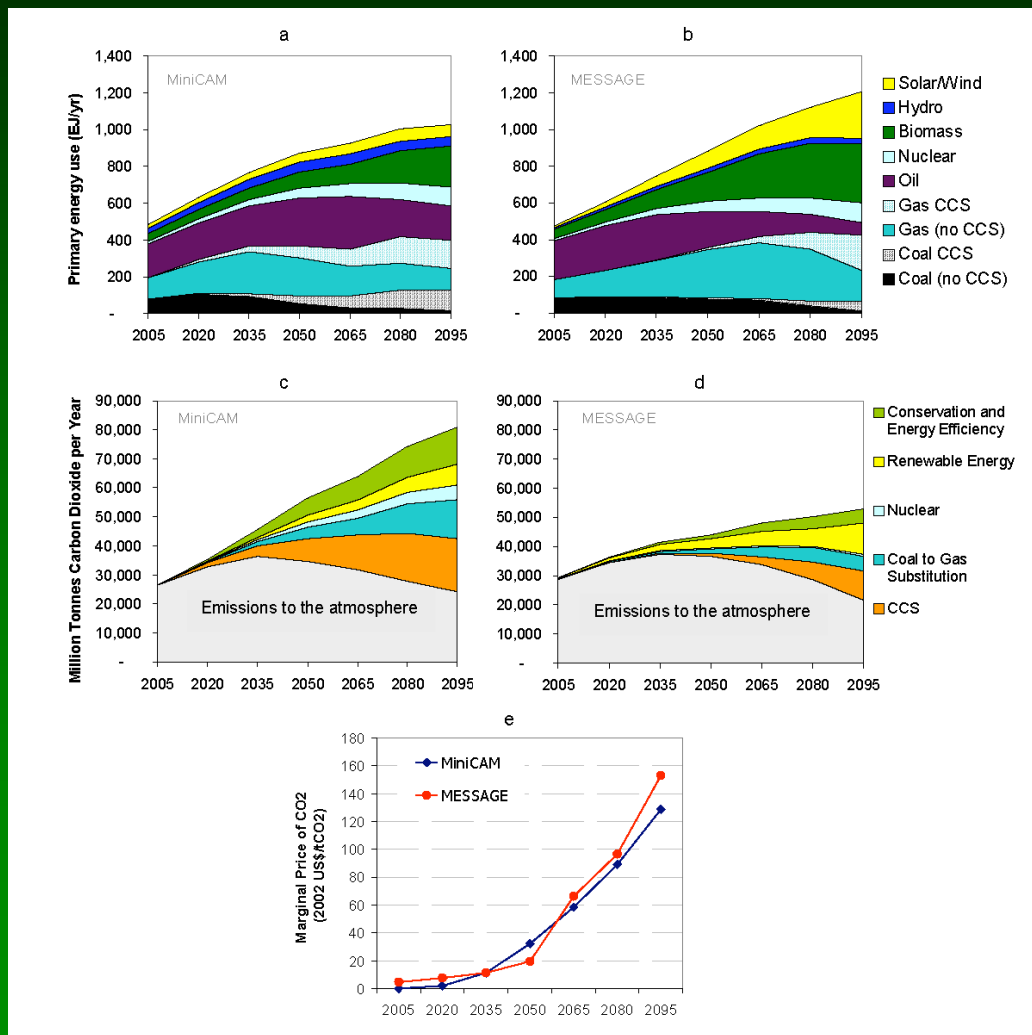

Figure S.7. These figures are an illustrative example of the global potential contribution of CCS as part of a mitigation portfolio. They are based on two alternative integrated assessment models (MESSAGE and MiniCAM) adopting the same assumptions for the main emissions drivers. The results would vary considerably on regional scales. This example is based on a single scenario and, therefore does not convey the full range of uncertainties. Panels a) and b) show global primary energy use, including the deployment of CCS. Panels c) and d) show the global CO₂ emissions in grey and corresponding contributions of main emissions reduction measures in colour. Panel e) shows the calculated marginal price of CO₂ reductions (8.3.3, Box 8.3).

Contact Information

- Web Site - sequestration.mit.edu
- Contact
 - Howard Herzog
 - Laboratory for Energy and the Environment (LFEE)
 - Room E40-447
 - 617-253-0688
 - hjherzog@mit.edu