

Rich Problems: Multiple Representations Using TI-Nspire™ Technology

Karen Droga Campe

karen.campe@yale.edu

www.yale.edu/tprep/about/faculty/campe



Teachers Teaching With Technology
International Conference
February 2009

TI-Nspire™ handheld keys

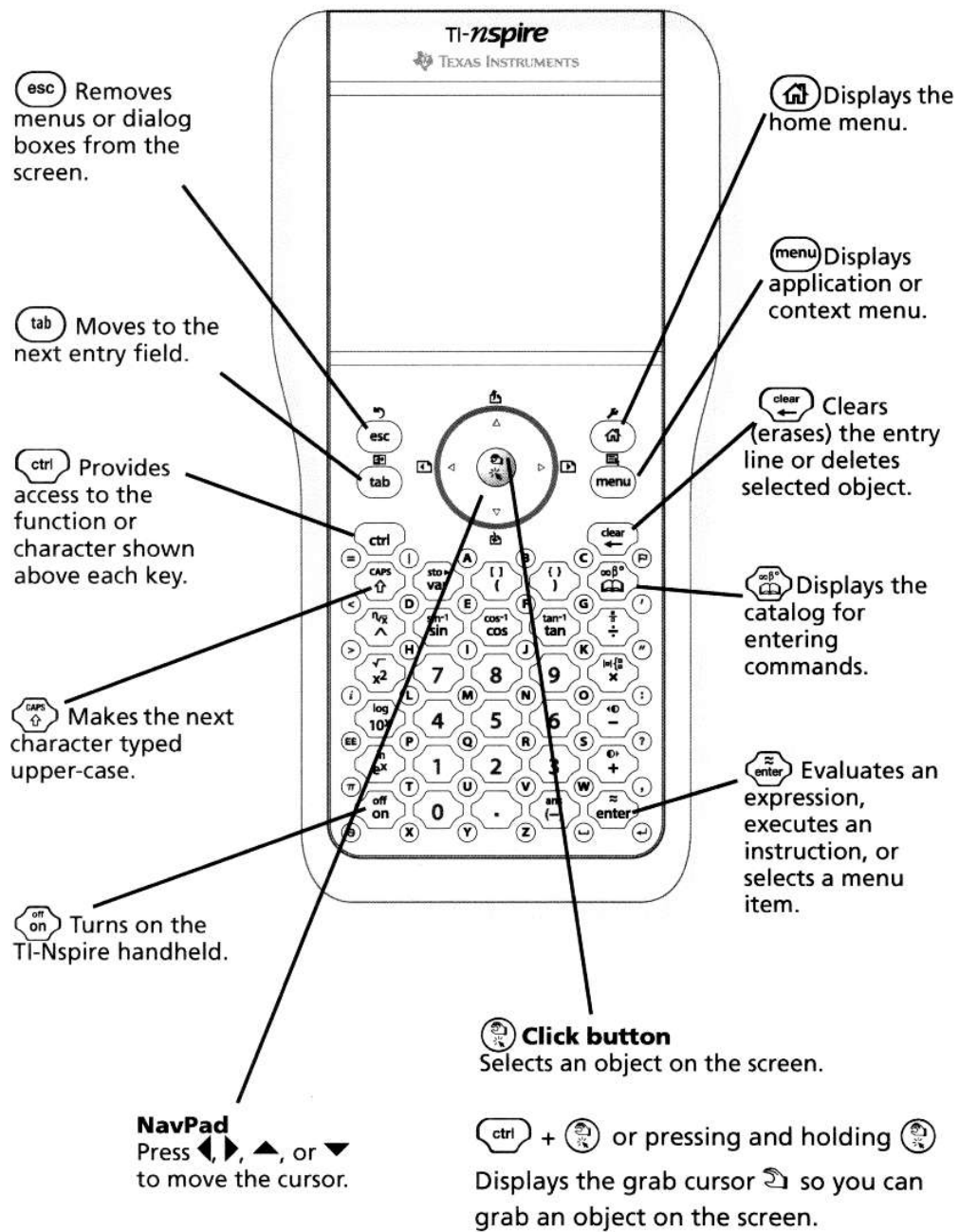

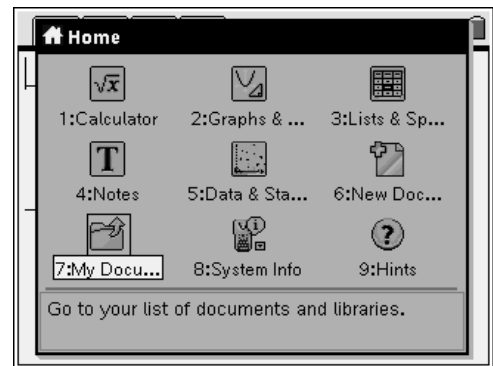

The Home Screen

- Create new documents
- Insert pages into existing documents
- Access My Documents
- Access System and Document Settings



Control Key Functions & Shortcuts

Page Tools Menu  press  

































- File and Edit tools (including Insert Page & Insert Problem)
- Move between pages
- Change Page Layout

Page Sorter  press  



- Displays thumbnails of all pages in current document

Context Menu  press  

- Displays options that are specific to the selected object or the current cursor location

Editing		Navigating		Managing Documents	
Cut	 	Previous Page	 	New Doc	 
Copy	 	Next Page	 	Insert Page	 
Paste	 	Up Level	 	Select Applic	 
Undo 	   	Down Level	 	Save Doc	 
Redo	 	Switch Layout Panels 	 		

Measurements in Graphs & Geometry

When using Measurement tools, the Coordinates & Equations tool, or the Calculate tool, press  or  one additional time after the pertinent objects are selected in order to anchor the measurement.

Menus for Each TI-Nspire Application (menu)

Calculator Application (non-CAS)

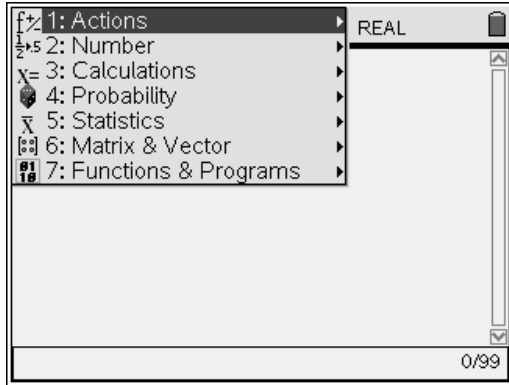

Calculator Application (CAS)

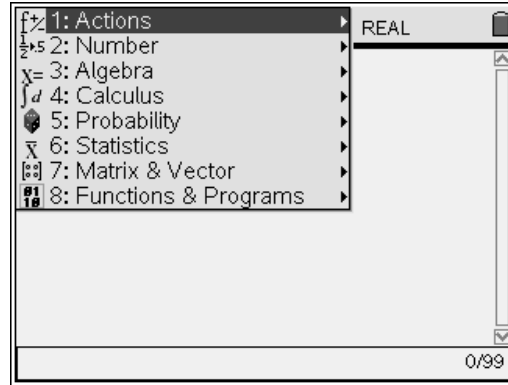

Graphs and Geometry Application

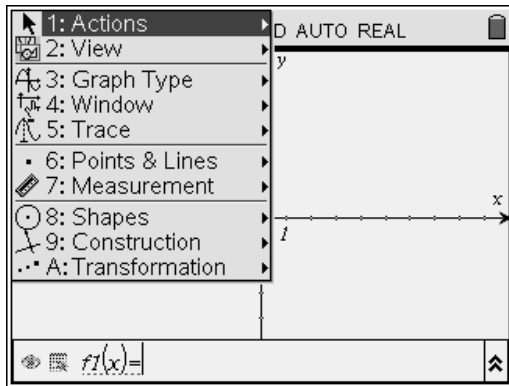

Lists and Spreadsheet Application

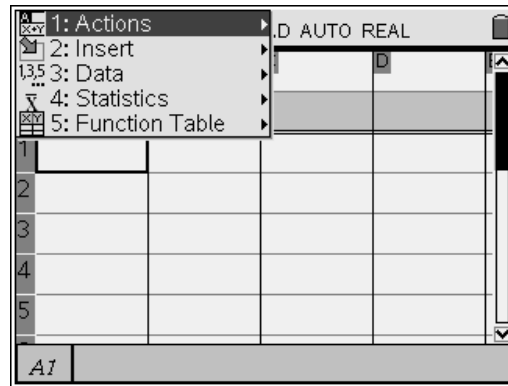

Data and Statistics Application

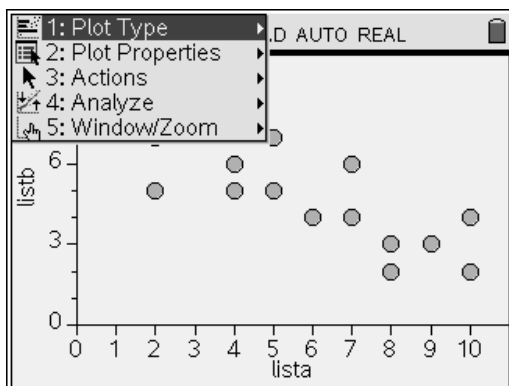

Notes Application

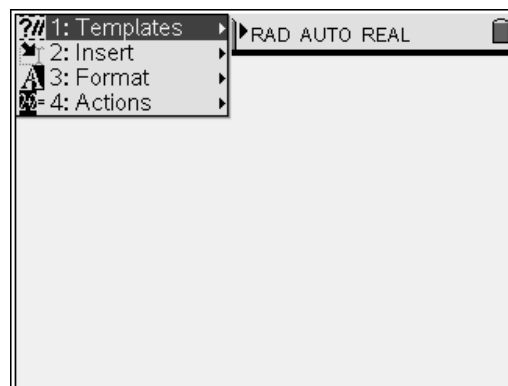

The Paper Folding Problem
Student Worksheet

Name _____

The Problem:

A rectangular piece of paper is folded so the upper left-hand corner just touches a point on the base of the rectangle. There is a triangle formed in the lower left-hand corner. What is the maximum area of this triangle?

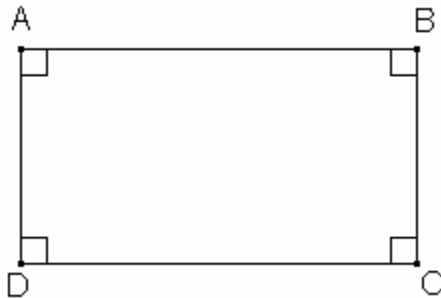

Figure 1a

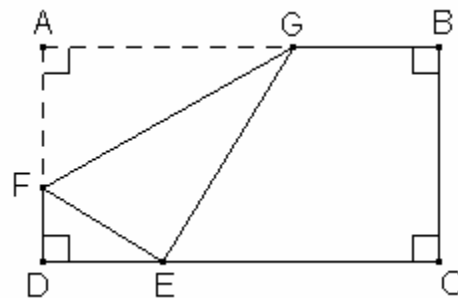

Figure 1b

The four vertices of the rectangle are labeled **A**, **B**, **C**, and **D** (Figure 1a). Fold vertex **A** of the rectangle so it just touches side **CD** and call this point **E** (Figure 1b). Determine the location of point **E** that maximizes the area of $\triangle EDF$.

Warmup: Paper Model

Take a rectangular piece of paper or graph paper and measure its dimensions in inches.

length _____ **width** _____

How many 1 inch squares could fit on that single sheet of paper? _____

Now fold the paper to model the problem. Estimate the area of $\triangle EDF$ by counting squares or calculating $Area = \frac{1}{2} \cdot Base \cdot Height$. Record values in inches

base DE _____ **height DF** _____ **area** _____

Compare your area to that of others. What do you think is the location of point **E** that makes the area of $\triangle EDF$ a maximum?

Problem 1: Explore

1. Open the .tns document PaperFolding in TI-Nspire. Explore the geometric model on page 1.5. Press $\text{ctrl} + \text{drag}$ to drag the point.
2. On page 1.7, drag point **E** along the bottom of the rectangle. Observe what happens to the area of triangle **DEF**.

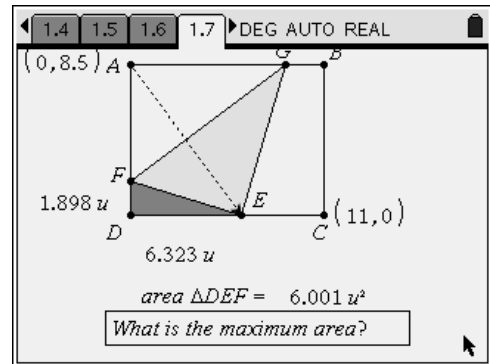

What is the largest value of the area?

3. What else can you find out about this maximum area $\triangle DEF$? Make some measurements such as angle measures and side length using the tools in the Measurement menu ($\text{menu} + 7$).
Note: to measure an angle, press $\text{ctrl} + \text{drag}$ on 3 points, with the vertex of the angle selected second.

Record your conjectures and discuss them with others.

Problem 2: Scatterplot

4. Enter the base and height of your paper triangle in the spreadsheet on page 2.2. Check that the area calculated in the spreadsheet agrees with your area calculation.
5. Enter the base and height for all the triangles formed in the class.
6. On page 2.4, look at the class data in a scatterplot.
 - Press $\text{menu} + 3$ for Menu: Graph Type.
 - Press $\text{menu} + 4$ for Menu: Window.

	A	B	C	D
	base	height	area	
			=base*height/2	
1				
2				
3				
4				
5				

7. On page 2.5, compare the class data scatterplot to the geometric model. Drag the point on the geometric model and observe the trace on the scatterplot.

What base length produces the triangle with maximum area?

Estimated base length _____

Estimated max area _____

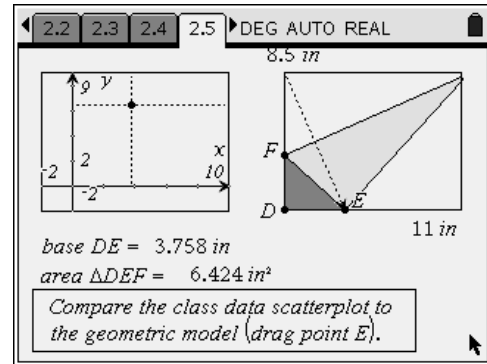

Problem 3: Algebraic Formula

8. Review the diagram in Figure 1b on Student Page 1.

Let the length of base **DE** = x

Let the length of height **DF** = y .

Can you explain why the hypotenuse **EF** = $8.5 - y$?

9. For what values of x does the triangle **DEF** not exist? Why?

What is the domain of the formula we will write for Area(x)?

10. Use the Pythagorean Theorem to develop an algebraic relationship between x and y . Find a formula for height y in terms of base x .

11. Substitute the formula you found for height y into $Area = \frac{1}{2} \cdot Base \cdot Height$ and simplify. Give the formula for Area (x).

What kind of function is Area(x)? _____

15. On page 4.5, set up a scatterplot of the captured data.

Press MENU \leftarrow 3 \leftarrow 4: for Menu: Graph Type, Scatterplot.

In the entry line, click CROSS on the drop-down boxes to designate the list variables.

XList = **lbase**, YList = **larea**.

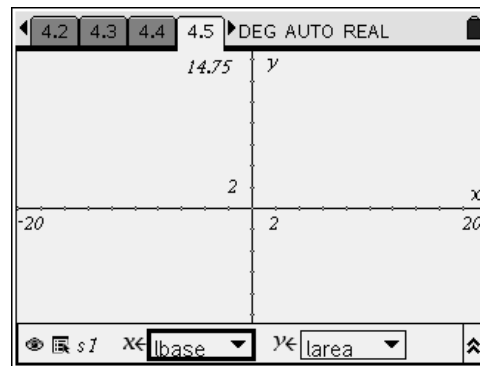

16. Press MENU \leftarrow 4 \leftarrow 1 for Menu: Window, Window Settings and input the values from step 14 above.

Examine the graph of the data. What type of function is appropriate to model the data? (Refer back to your function from step 11).

17. On page 4.6, perform a statistical calculation on the data.

Press MENU \leftarrow 6 \leftarrow 1: for Menu: Statistics, Stat Calculations and select the type of regression model supported by the data (step 16) and the algebraic model (step 11). [MENU \leftarrow 5 non-CAS]

In the Regression box that appears, select **lbase** for X List and **larea** for Y List and save the regression equation to f1. Click on OK.

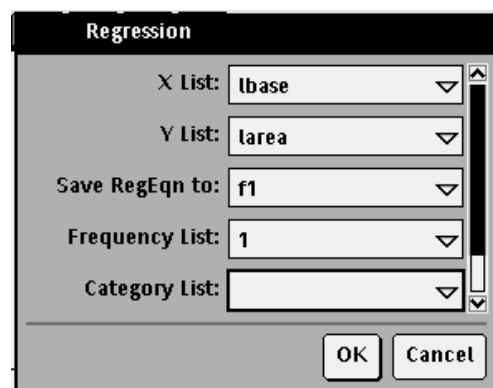

18. Press CTRL \leftarrow to return to the graph on page 4.5 and view the graph of the regression equation along with the scatterplot of captured data.

Press MENU \leftarrow 5 \leftarrow 1 for Menu: Trace, Graph Trace to estimate the maximum value of the function. Record the values below.

X (**base**) _____ Y (**area**) _____

19. Compare the regression result with the algebraic model from step 11.

Problem 5: Calculus Solution Using CAS Tools (Extension)

20. On Calculator page 5.2, find the derivative of the Area(x) function from step 11, then solve the equation $\frac{d}{dx}(Area(x)) = 0$.

- Press $\text{[menu]} \text{[4]} \text{[1]}$ for Menu: Calculus, Derivative.
- Press $\text{[menu]} \text{[3]} \text{[1]}$ for Menu: Algebra, Solve.

21. How does the calculus solution compare with the solutions found through other methods?

22. How is the height y of the maximum area triangle related to the original width of the paper (8.5 inches)?

Problem 6: A Trigonometry Approach (Extension)

23. Consider the measure of $\angle DFE$ and how it is related to the area of $\triangle DEF$. Explore the geometric model on page 6.2.

If the measure of $\angle DFE = \theta$, what value of θ appears to give the triangle of maximum area?

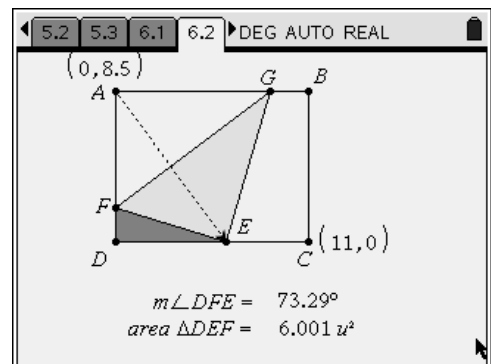

24. Use any of the above approaches (data capture, algebraic model, CAS solution) to justify your conclusion.

Regular Polygons

Student Worksheet

Name _____

Class _____

In this activity, you will explore regular polygons and their interior, exterior & central angles.

Definitions needed:

- A regular polygon is a polygon whose sides all have equal length and whose angles all have equal measure.
- An exterior angle of a polygon is formed when one of the sides is extended.
- A central angle of a polygon is the angle between 2 consecutive radii formed from consecutive vertices.
- An interior angle of a polygon is the inside angle between consecutive sides.

1. Open the *Reg Polygons.tns* document, and construct a regular pentagon on page 1.3.

- Press MENU $\{8\}$ $\{5\}$ for Menu: Shapes: Regular Polygon.
- Click POINT once to locate the center point of the polygon.
- Move the cursor away from the center point, and click POINT a second time to establish the first vertex and radius. A 16-sided polygon is formed as a default (Figure A).
- Select a vertex, and move it clockwise to reduce the number of sides, or counterclockwise to increase the number of sides (Figure B).
- Click POINT to finish the polygon.

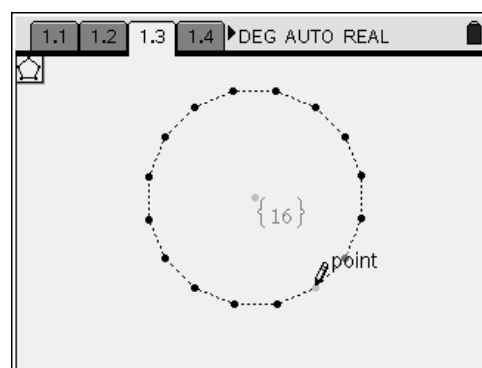

Figure A

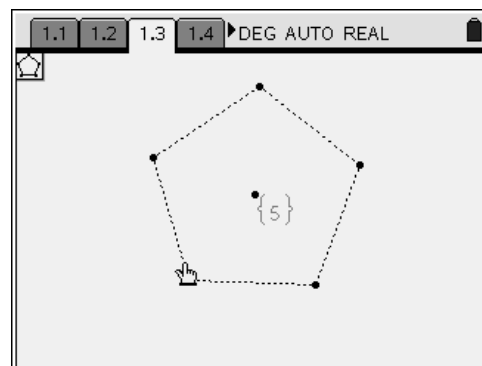

Figure B

2. Explore the properties of the pentagon, and circumscribe a circle around it.

What properties make it possible to inscribe a regular polygon in a circle?

3. What is a side of the regular polygon called with respect to the circumscribed circle?

4. What is the measure of a central angle of a pentagon?

What formula can you use to calculate the measure of a central angle for any regular polygon?

5. Move to page 1.4 where a partial regular polygon has been constructed by rotating a point on a circle.

- Many measurements have been made for you.
- **EA** represents the measure of the exterior angle.
- **s** is the number of sides.
- **CA** is the measure of the central angle.
- **IA** is the measure of the interior angle.

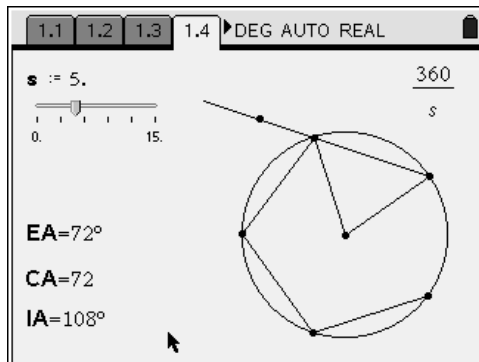

6. Capture the current data by pressing **ctrl** + **⏏**.

7. The variable **s** is controlled by a slider. Press **ctrl** + **⏏** to grab the slider control.

Change the number of sides to create several other polygons (use 4, 5, 6, 8, 9, 10, and 12 sides).

After each edit, capture the data (**ctrl** + **⏏**).

- **Note:** There is no need to switch pages while capturing.

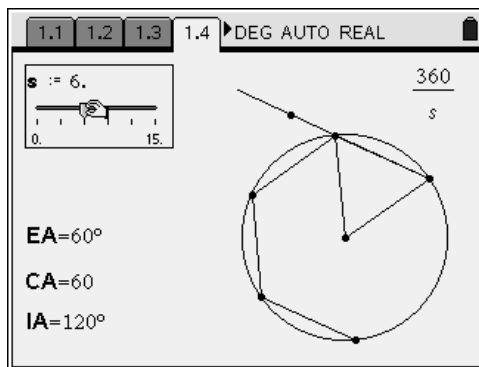

8. Record the data from the spreadsheet on page 1.5 into the chart below.

Number of Sides	Central Angle Measure	Interior Angle Measure	Exterior Angle Measure

9. Look for patterns in your data. What happens to the different angle measures as the number of sides increases?

10. Return to the spreadsheet page 1.5.

In column E, use the name `sumint`, and create a formula in the row marked with \blacklozenge to find the sum of the interior angles of the polygon. Use two of the columns' names to create the formula.

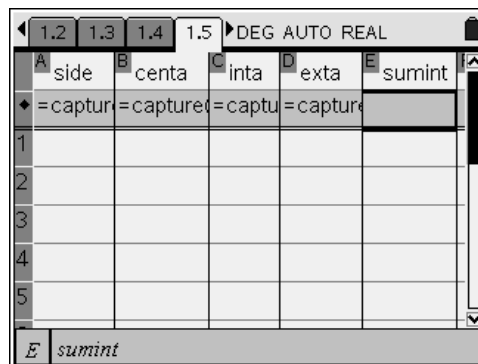

11. Add a new Graphs & Geometry page, and create a scatterplot to graph the relationship between the number of sides and the sum of the interior angles.

- Press MENU $\langle 3 \rangle$ for Menu: Graph Type
- Press MENU $\langle 4 \rangle \langle 1 \rangle$ for Menu: Window: Window Settings

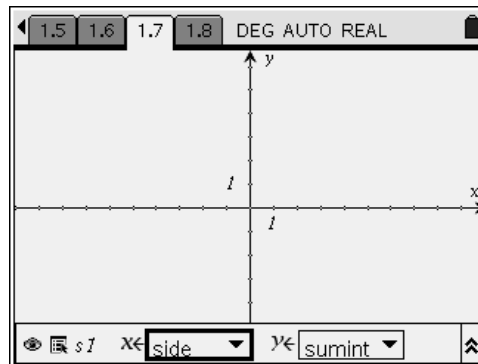

12. Add a new Calculator page, and perform a linear regression of the number of sides versus `sumint` (sum of interior angles).

- Press MENU $\langle 6 \rangle \langle 1 \rangle$ for Menu: Statistics: Stat Calculations

13. What formula can you use to calculate the sum of the interior angles of a regular polygon if you know only the number of sides?

14. Add a new Graphs & Geometry page, and create a new scatterplot to graph the relationship between the number of sides and the measure of an exterior angle of the polygon (`exta`). Try different regression models to get a good fit.

15. What formula can you use to calculate the size of one exterior angle of a regular polygon if you know only the number of sides?

The Lunes of Hippocrates	Name _____
	Class _____

In this activity, you will explore a figure involving circles and a right triangle.

A *Lune* is the area enclosed between arcs of intersecting circles

Use this document to record your answers.

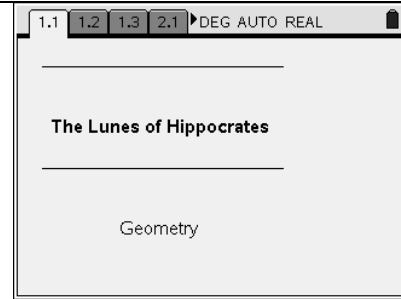

Problem 1 – Constructing the Lunes

Open the file *Lunes*.

- On page 1.3, construct a segment \overline{AC} and a perpendicular line through point C. Then create point B on the perpendicular line, and use the **Triangle** tool to draw $\triangle ABC$.
- Hide the perpendicular line, and construct the midpoints of the sides of $\triangle ABC$.
- Use the midpoints as centers of 3 circles. Each circle will have a side of $\triangle ABC$ as its diameter.
- Measure the areas of the three circles and the triangle.
- Use the expression $\frac{\text{circle}}{2}$ to calculate the areas of the 3 semicircles.

Problem 2 – Sum of the Areas of the Lunes

Use your figure on page 1.3 or the pre-made figure on page 2.2 to continue.

- Record the areas of the semicircles below. Drag a vertex of $\triangle ABC$ to get different values.

semiAC	semiBC	semiAB

- Do you notice a relationship between the areas of the 3 semicircles? Make a conjecture.
- What well-known theorem justifies this result?

9. On page 2.3, the lunes are defined as the regions *inside* the two small semicircles (with diameters \overline{AC} and \overline{BC} , but *outside* the large semicircle (with diameter \overline{AB}).

What areas would you add and subtract to find the sum of the areas of the lunes? Write a formula below:

Sum of the Lunes = _____

10. Record the data you collected in the spreadsheet on page 2.6.

triangle	semiAC	semiBC	semiAB	lunes

11. What do you notice about the area of the lunes and another area already found?

12. Complete the conjecture:

The sum of the areas of the lunes = _____

13. On page 2.8, drag point A, B or C to change the triangle's shape and observe if your conjecture is true.

Problem 3 – Algebraic Approach (Extension)

14. Let a = length of side \overline{BC} , b = length of side \overline{AC} , and c = length of side \overline{AB} .

Write expressions for the areas of the triangle and semicircles in terms of a , b , and c .

Area triangle = _____ Area semiAC = _____

Area semiBC = _____ Area semiAB = _____

15. Substitute your expressions into your formula from #9 above and simplify.